



# NOTICE DE MONTAGE DU BLOC SERRURE UNIVERSEL

## INSTRUCTIONS FOR INSTALLING THE LOCK BLOCK

### ISTRUZIONI DI MONTAGGIO DEL BLOCCO SERRATURA UNIVERSALE



ref: BSA / BSM

**AVERTISSEMENT:** Le non respect des instructions de montage dégage la responsabilité du fabricant. BSA incompatible avec la PEC, PCM, POM.

**WARNING:** Failure to follow installation instructions releases the manufacturer from liability. BSA incompatible with PEC, PCM, POM.

**ATTENZIONE:** il produttore non si assume alcuna responsabilità qualora non siano rispettate le istruzioni di montaggio.

BSA incompatible with PEC, PCM, POM.

Pour transformer le BSA en BSM: retirer le ressort.  
To convert the BSA into a BSM: withdraw the spring.  
Per trasformare il BSA in BSM, ritirare la molla



#### A. USINAGES DES PROFILES

##### MACHINE-WORK ON PROFILES LAVORAZIONE DEI PROFILI:

X= Se reporter au plan du fournisseur du profilé  
Refer to profile manufacturer's drawing  
Riferirsi al progetto del fornitore del profilo

Y= Se reporter au plan du fournisseur du profilé  
Refer to profile manufacturer's drawing  
Riferirsi al progetto del fornitore del profilo

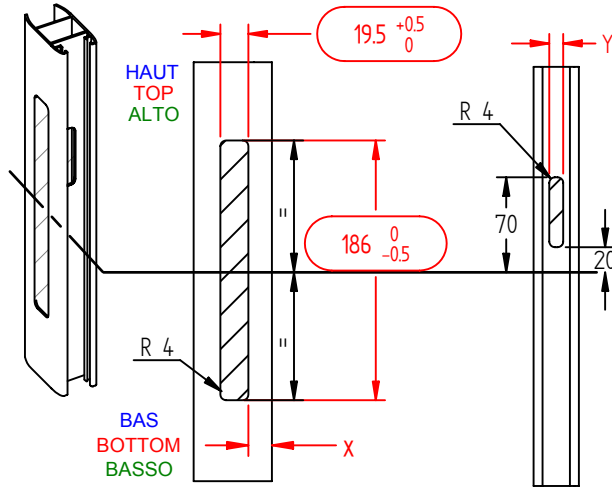

#### B. MONTAGE DU BLOC SERRURE

##### INSTALLING THE LOCK BLOCK

##### MONTAGGIO DEL BLOCCO SERRATURA :

Outil: TOURNEVIS PLAT Ø 5 mm Tool: Ø 5mm FLAT-EDGE SCREWDRIVER Utensile: GIRAVITE PIATTO con diam. 5 mm

Engager bloc serrure , coté fourchette sortie sous la toile dans le bas du profil.

Attention: support de pêne en face de l'usinage feuillure !

Engage the lock block, tabs outward, under the edge at the bottom of the profile.

Inserire il blocco serratura, con il lato forchetta fuoriuscito, nella parte bassa della lavorazione sul profilo.

Attenzione: la sede del nasello deve essere visibile alla relativa lavorazione !

Engager selon détail photo.

Engage as shown in photo.

Inserire come dettaglio foto.

Appuyer fort et engager à fond la fourchette haute sous la toile en basculant le tournevis. Puis vérifier que les fourchettes soient poussées à fond.

Press hard and engage the top tab completely under the edge while rocking the screwdriver. Then, check that the tabs are pushed in completely.

Spingere forte ed inserire a fondo la forchetta sotto la lavorazione del profilo capovolgendo il giravite. In seguito verificare che le forchette sono spinte sino al fondo.

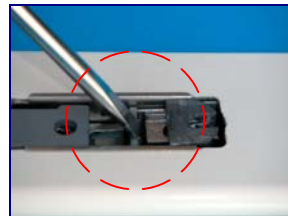
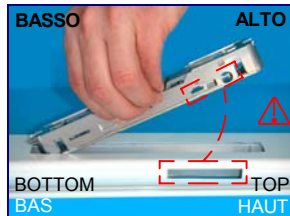

#### C. MONTAGE DE L'ANTI-FAUSSE MANOEUVRE (AFM)

##### INSTALLING THE ANTI-DERAIL (AFM)

##### MONTAGGIO DELL'ANTI-FALSA MANOVRA (AFM):

4. Placer le coulisseau en position basse (position ouverte).  
Placer l'AFM avec la flèche du côté sortie pêne.  
5. Clipser l' AFM et vérifier sa bonne tenue

4. Place the glide in the low position (open position).  
Place the AFM so that the arrow points to the bolt outlet.  
5. Clip on the the AFM and make sure it holds.

4. Posizionare la vaschetta verso il basso (posizione aperta). Sistemare AFM con la freccia posizionata verso l'uscita del nasello.  
5. Far scattare AFM e verificarne la tenuta.

④



⑤



#### D. MONTAGE DU PION ANTI-FAUSSE MANOEUVRE ET REGLAGE DU PÊNE

##### INSTALLING THE ANTI-DERAIL SLUG AND ADJUSTING THE BOLT

##### MONTAGGIO DEL PIOLO ANTI-FALSA MANOVRA E REGOLAZIONE DEL NASELLO:

Outil: CLE 6 PANS de Ø 3 mm.

6. Visser avec modération le palpeur anti-fausse manoeuvre jusqu'au blocage.  
7. Vérifier le sens du pêne, devant être toujours centré dans la feuillure.  
8. Engager le pêne jusqu'à sa butée dans son logement et serrer avec modération.

⚠ Ne pas ôter le gabarit orange du pêne, car il permet le réglage de la gâche sur chantier avant la pose des parements.

Tool: Ø 3 mm hex wrench.

6. Moderately screw in the anti-derail key lever until it is locked in place.  
7. Check the position of the bolt, it must always be centered in the groove.  
8. Engage the bolt to its stop in its bore, and tighten moderately.

⚠ Do not remove the orange jig from the bolt, as it will be needed when adjusting the lock-bolt keeper on the construction site before installation of facing.

Utensile: chiave esagonale 3 mm

6. Avvitare con moderazione il piolo anti-falsa manovra fino al blocco.  
7. Verificare il senso del nasello che deve essere sempre centrale nella fessura.  
8. Inserire il nasello fino al suo stop nel suo alloggiamento e stringere con moderazione.

⚠ (Ove prevista) Non togliere la mascherina arancione dal nasello in quanto consente la regolazione del riscontro su cantiere prima della messa in posa del serramento.

⑥



⑦ ⑧

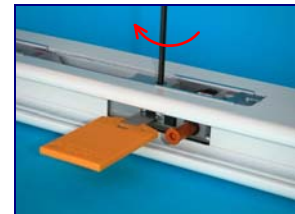

#### E. DEMONTAGE DU BLOC SERRURE

##### REMOVING THE LOCK BLOCK

##### SMONTAGGIO DEL BLOCCO SERRATURA:

(à titre exceptionnel, après démontage du pion d'AFM et du pêne)

(remove only when necessary after removing the AFM key lever and the bolt's key lever)

(rimuovere solo quando necessario dopo aver tolto AFM e il nasello)

Outil: PETIT TOURNEVIS PLAT de 3 mm.  
Introduire le TOURNEVIS entre le profil et la fourchette selon détail photo, puis faire basculer.

Tool: SMALL 3 mm FLAT-EDGE SCREWDRIVER.  
Insert the screwdriver between the profile and the tabs, as shown in photo, then use the screwdriver as a lever.

Utensile: piccolo giravite piatto di 3 mm.  
Introdurre il giravite fra il profilo e la forchetta secondo dettaglio foto, poi far leva.

①



②

